

PLASTIC COLLAPSIBLE CONTAINER (WITH BASE PALLET)

48x42

**CLEAN BY DESIGN.
EFFICIENT BY NATURE.
BUILT FOR DEMANDING
ENVIRONMENTS.**

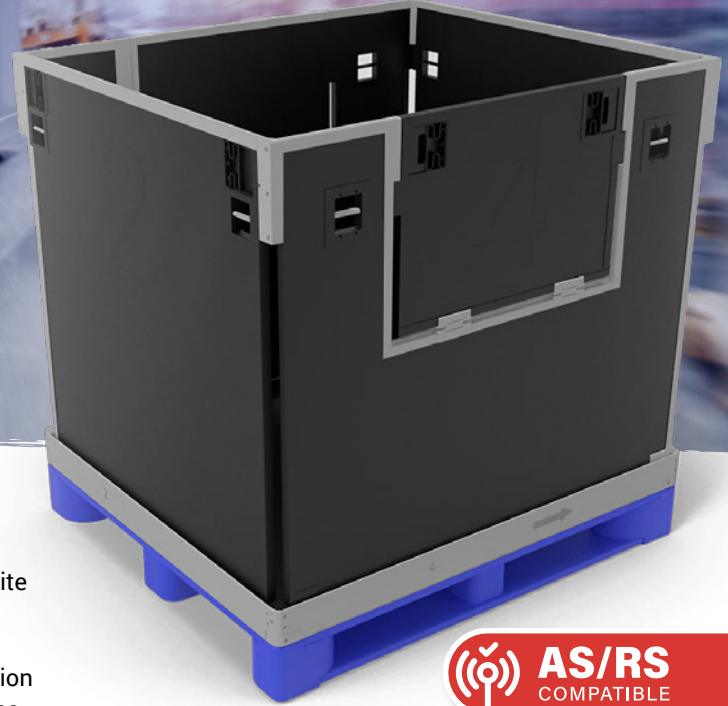

BUILT FOR CLEAN, SPACE-EFFICIENT HANDLING

The Plastic Collapsible Container with Base Pallet from Artistic Composite Pallets is designed for industries that demand **maximum sanitation, durability, and space efficiency**. Constructed from FDA-compliant materials and optimized for washdown environments, it's the ideal solution for food, beverage, pharmaceutical, and clean manufacturing applications. With its collapsible design, this container delivers **reduced storage costs, easier return logistics, and long-term value**.

KEY FEATURES & OPTIONS

- Collapses to 9.1" Height (Stackable)
- Durable & Cost Effective
- Wash Down Capability (FDA Compliant Materials)
- Removable Panels on Two Walls for Easy Product Access
- Durable Spring Latches Keep Walls Secure
- Custom Sizes and Load Capacities Available
- Ability to insert RFID and IoT tags for tracking
- Fork Pocket Entry: 4-Way (48" Side or 42" Side)
- Fork Pocket Openings:
48" Side: 14.42" W x 3.68" H
42" Side: 12.32" W x 3.68" H

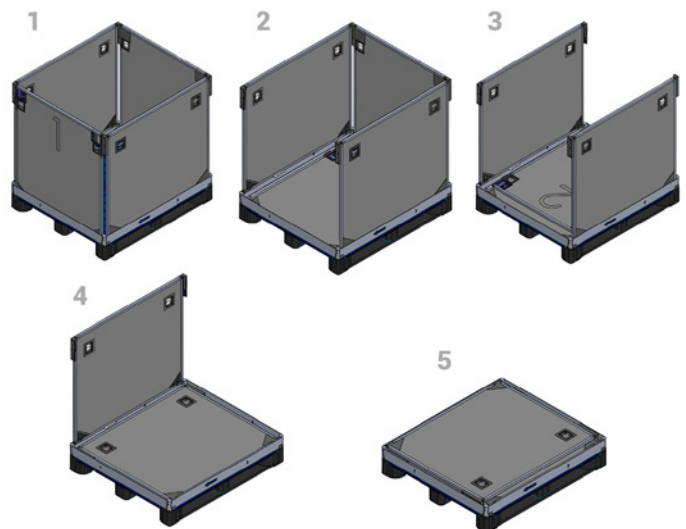

PRODUCT SPECIFICATIONS

PRODUCT	DESCRIPTION	EXT. DIMENSIONS			WEIGHT	LOAD CAPACITY		MATERIAL CONSTRUCTION
		L	W	H		RACKABLE	DYNAMIC	
PCC 48x42	Plastic Collapsible Container with Base Pallet	48"	42"	46.9"	130 lbs.	2,000 lbs.	5,000 lbs.	Walls: Polypropylene Skins with closed-cell Polyethylene Foam Core Edges: Aluminum Channel Reinforcement
		INT. DIMENSIONS						
		46"	40"	41.3"				

WHY CHOOSE ARTISTIC COMPOSITE PALLETS?



SUPERIOR STRENGTH & DURABILITY

Engineered to meet GMA standards while exceeding ISO and ASTM benchmarks. With minimal deflection under load, it's ideal for automated material handling.



WASHDOWN-READY & FDA-COMPLIANT

Perfect for industries requiring high sanitation. No need for fumigation or heat treatment like wood pallets. Resists bacteria, mold, and pests.



SUSTAINABLE AND RECYCLABLE

Made from FDA-approved, recyclable materials that support a circular supply chain and reduce landfill use.



AUTOMATED SYSTEM COMPATIBLE

Seamless integration with pallet conveyors, dispensers, robotic palletizers, AS/RS, and pallet shuttle systems.



SAFETY FIRST

Splinter- and nail-free to protect your workers and your products.



LONG-TERM COST SAVINGS

Up to 50+ trips in open-loop use with a lifespan that matches the life of your automation equipment in closed-loop systems.

IDEAL APPLICATIONS



GENERAL
WAREHOUSING



FOOD & BEVERAGE
WAREHOUSING



PHARMACEUTICAL
MANUFACTURING



AUTOMATED STORAGE
& RETRIEVAL SYSTEMS
(AS/RS)

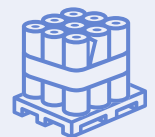

CONSTRUCTION
SUPPLY FACILITIES



SCAN TO LEARN MORE

READY TO SEE
THE ARTISTIC DIFFERENCE?

CALL US TODAY AT **317-960-5813**

or visit ArtisticPallets.com to request a quote and explore our gallery of customization options

